

Handdetektor für AM-Etiketten

Erleichtert die Kundenansprache, hilft beim Auffinden der Alarmursache und vermeidet falsche Kundenverdächtigungen

Features:

- Ergonomic design for handheld
- Rechargeable lithium battery
- Shrink theft and reduce mistake by false alarm

Specification:

- Frequency range: 57.2KHz-58.8KHz
- Power supply: 100--240VAC, 50Hz/60Hz, 0.30A
- Input: 12--15VDC
- Output: 12VDC, 1.25A
- Idle current: <120mA
- Beep current: <200mA
- Detection speed: 120pcs/min
- Detection height: 25cm
- Environmental: Operating temperature: 5° C to 40° C (41° F to 104° F). Relative humidity: 20% to 85% Non-Condensing.

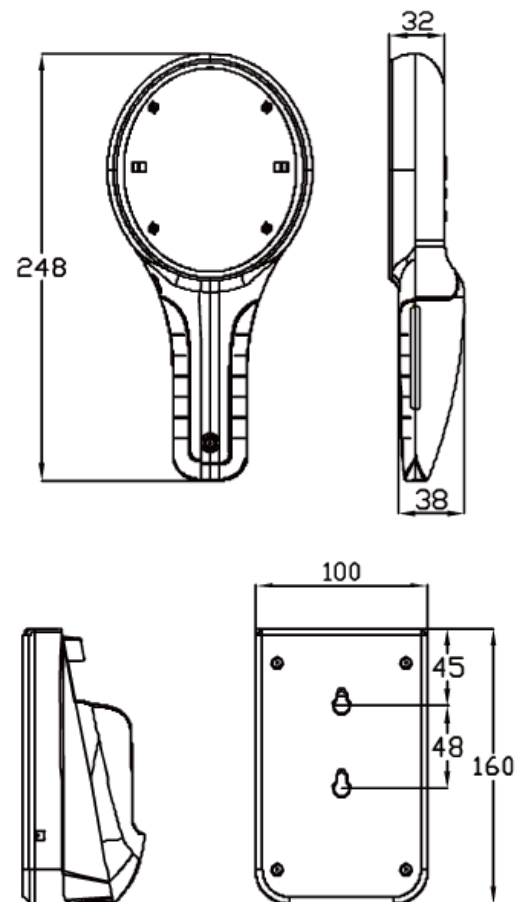

WG Global GmbH

Sägewerkstraße 3
D- 83416 Surheim

Email: info@wgglobal.eu

D: Tel. +49 8654 7715-0 **Fax:** -29

A: Tel. +43 810 900 313-0 **Fax:** -29

www.wgglobal.de